

From: [Timothy T. Callas](#)
To: [Boyle, Douglas J \(DHS\)](#)
Subject: FW: Local PIV Variance - Zores Towing BLDG 7
Date: Tuesday, November 5, 2019 4:26:22 PM
Attachments: [Local Variance Request PIV Zores # 2544.1.009.7.101 11-05-19.pdf](#)
Importance: High

**** This is an EXTERNAL email. Exercise caution. DO NOT open attachments or click links from unknown senders or unexpected email. ****

Doug,

We have requested a local PIV variance from Wayne Township Fire Department pursuant to IC 22-13-2-7(b). Attached is the variance request letter and below is WTFD approval response.

Thank you,

Tim Callas

From: Randy Gulley [mailto:Randy.Gulley@WayneTwp.org]
Sent: Tuesday, November 05, 2019 4:20 PM
To: Timothy T. Callas
Subject: Re: Local PIV Variance - Zores Towing BLDG 7

Tim, thank you for your letter of November 5, 2019 requesting a variance from the Indianapolis-Marion County Fire Prevention Ordinance Section 591-406. Which has adopted the 1995 Edition of NFPA 24 has a guide. In Section 3-3.2 of the aforementioned standard it states that the PIV shall be at least 40 feet away from building. This requirement in today's property and building standards and technology is no longer practical in my opinion as a Fire Marshal for Wayne Township Fire Department. Therefore, I have no problem granting a variance from this standard in regards to the 40 foot distance and the bury depth of the PIV located at 1300 North Mickey Avenue.

Randy Gulley, Fire Marshal
Wayne Township Fire Department
700 North High School Road
Indianapolis, IN. 46214

Get [Outlook for iOS](#)

From: Timothy T. Callas <tcallas@jtconsult.us>
Sent: Tuesday, November 5, 2019 3:45:20 PM
To: Randy Gulley <Randy.Gulley@WayneTwp.org>
Subject: FW: Local PIV Variance - Zores Towing BLDG 7

Randy,

Please find attached local PIV variance letter that was cited by Indianapolis bldg Department. This letter is a format that Margie uses. Also below in Margie's approval response, so if you could use her approval template then once you send this to me I

forward to Doug Boyle to place on the commissions Agenda for local variance

From: Bovard, Margie F. [mailto:Margie.Bovard@indy.gov]
Sent: Monday, November 04, 2019 9:08 AM
To: Timothy T. Callas
Cc: Bovard, Margie F.
Subject: FW: Local Variance - 727 N Illinois St

November 4, 2019

RE: Local Variance
727 Illinois Street Hybrid Building
727 North Illinois Street
Indianapolis, Indiana 46204

Dear Mr. Callas

Thank you for your letter dated [October 31, 2019](#) requesting a local variance from Section 591-406, Chapter 591 of the Indianapolis-Marion County Fire Prevention Code which adopts NFPA 24, 1995 Edition, Section 3, requiring a post indicator valve for a fire service water supply line.

Your request and justifications for a variance from the provisions of Chapter 591-406 is in compliance with the provision of Section 591-246, Chapter 591 of the Indianapolis-Marion County Fire Prevention Code which was passed by the City-Council on April 29, 2002 and signed by Bart Peterson on May 2, 2002, and approved by the Fire Prevention and Building Safety Commission on May 8, 2002.

Based on the items listed in your letter dated [October 31, 2019](#), a local variance to the above mentioned Section is granted by the Indianapolis Fire Department. [In accordance with the exception to NFPA 24, Section 3-3.2, a post Indicator valve will not be located 40' away from the building due to location of property lines and site restrictions. A wall mounted post indicator valve will be located on the south west corner of the building giving adequate access from Illinois Street.](#)

This approval must be presented to the Fire Prevention and Building Safety Commission as per IC 22-13-2-7. "The Commission shall review variances granted by a political subdivision to the fire safety laws and building laws adopted in its ordinances". This variance is not effective until it is approved by the Commission. There is no fee but the item must be placed on the Commission's agenda. Please contact Denise Fitzpatrick at the Indiana State Fire Prevention and Building Safety Office 317-232-6213 to place this item on the next Commission meeting agenda.

If you have any questions, feel free to contact me at 317-327-5529 or margie.bovard@indy.gov

Respectfully
Margie Bovard
Senior Fire Cod Plans Examiner
Indianapolis Fire Department.

November 5, 2019

Mr. Randy Gulley
Wayne Township Fire Department
Battalion Chief Fire Prevention
700 North High School Road
Indianapolis, Indiana 46214-3700

**ZORES TOWING – BUILDING 7
1300 NORTH MICKLEY AVENUE
INDIANAPOLIS, INDIANA 46224**

PIV LOCAL VARIANCE REQUEST

Mr. Gulley,

J & T Consulting, LLC is requesting a variance to the Marion County Code Section 591-406 that requires a post indicator valve on a private fire main for the Zores towing - Building 7 located at 1300 Mickley Avenue. The requirement for the post indicator valve more than 40 feet away from building creates difficulties for this project due to the building is surrounded by towing truck lanes and adjacent buildings (see site drawing enclosed for location). In addition the height of the PIV is 10 inches shorter from top of pavement than what is required. This location provides the necessary access, is located out of the way, and does not obstruct the fire lane. For these reasons, we are requesting a local variance as proposed.

If you have any questions or require additional information, please do not hesitate to contact my office.

Very truly yours,

Timothy T. Callas

Timothy T. Callas
Principal

#2544.1.009.6.7.101

GENERAL NOTES

Property description based on information supplied by client. Relocation of existing incoming services shall be in accordance with local utility's specifications.

All existing and pending structures, including underground pipes and utilities, shall be properly protected at all times by the each Sub-Contractor. Existing features shall be located by each respective Sub-Contractor for specific scope and field verified with existing conditions.

All building construction work, alterations, repairs, and mechanical installations connected therewith shall comply with all the State Building Rules and Regulations. Local Ordinances shall be followed.

This includes the latest editions of the following volumes of the State Building Codes: UBC, IMC, IEC, LSC, OSHA, together with the latest revised building code of the applicable Federal, State, City, and County, etc.

This project has been designed under the 2012 International Building Code as amended and adopted by the State of Indiana. The Contractor(s) shall verify that all work is in conformance with the applicable Codes and Regulations. If any unresolvable conflicts arise as to the intent of these designs or construction, it is hereby agreed by all parties that the rules of the American Arbitration Association shall prevail. In the event of deviation between the Drawings and provisions of the Codes and Regulations, the Code and Regulation requirements shall apply.

The owner shall notify the Registered Architect/Engineer promptly of completion so that the final inspection can be scheduled from the State Fire Marshall before occupancy in accordance with State Statutes.

Drawings are diagrammatic and schematic and indicate the general arrangement only. Each Sub-Contractor shall make his work complete and perfect in all respects and ready for operation. All required work, even if particularly not specified, shall be furnished and installed by each Sub-Contractor without additional expense to the Owner. Drawings are at such a scale that it is not possible to indicate offsets, fittings, and accessories which may be required by each respective Sub-Contractors.

SITE PLAN NOTES:

- CONTRACTOR SHALL REFER TO ARCHITECTURAL PLANS FOR EXACT LOCATIONS AND DIMENSIONS OF BUILDING, SIDEWALKS, EXIT PORCHES, RAMPS, AND EXACT BUILDING UTILITY ENTRANCE LOCATIONS.
- ALL UN-SURFACED AREAS ARE TO RECEIVE FOUR INCHES OF TOPSOIL, SEED, MULCH, OR SOD, AND WATERED UNTIL A HEALTHY STAND OF GRASS IS OBTAINED AS INDICATED ON THE LANDSCAPING PLAN.
- PROPERTY & TOPOGRAPHIC SURVEY WAS PROVIDED BY OWNER
- CONTRACTOR IS RESPONSIBLE FOR PROTECTING EXISTING BENCHMARK.
- (OMITTED)
- CONTRACTOR SHALL BE RESPONSIBLE FOR ALL RELOCATIONS, INCLUDING BUT NOT LIMITED TO ALL UTILITIES, STORM DRAINAGE, SIGNS, ETC. AS REQUIRED FOR WIDENING OF ALL ROADWAYS. ALL WORK SHALL BE IN ACCORDANCE WITH GOVERNING AUTHORITIES SPECIFICATIONS AND SHALL BE APPROVED BY SUCH. ALL COSTS SHALL BE INCLUDED IN THE BASE BID.
- EXISTING UTILITY LINES SHOWN ARE APPROXIMATE LOCATIONS ONLY. THE CONTRACTOR SHALL FIELD VERIFY ALL EXISTING UTILITY LINE LOCATIONS PRIOR TO ANY CONSTRUCTION. ANY DEVIATIONS FROM THE DESIGN LOCATIONS SHALL BE REPORTED TO THE OWNER OR ENGINEER PRIOR TO CONSTRUCTION.
- CONTRACTOR SHALL REFER TO ARCHITECT'S PLANS AND SPECIFICATIONS FOR ENTRY LOCATION OF ALL WATER, SEWER SERVICE, ELECTRICAL, TELEPHONE AND GAS SERVICE. CONTRACTOR SHALL COORDINATE INSTALLATION OF UTILITIES IN SUCH A MANNER AS TO AVOID CONFLICTS AND ASSURE PROPER DEPTHS ARE ACHIEVED AS WELL AS COORDINATING WITH THE REGULATORY AGENCY AS TO THE LOCATION AND TIE-INS/CONNECTIONS TO THEIR FACILITIES.
- NOT USED
- ALL DIMENSIONS SHOWN TO BUILDING ARE TO OUTSIDE FACE OF BUILDING. ALL NECESSARY PERMITS AND APPROVALS FROM AGENCIES GOVERNING THE CONSTRUCTION OF THIS WORK SHALL BE SECURED PRIOR TO BEGINNING CONSTRUCTION.
- CONTRACTOR IS RESPONSIBLE FOR THE PROTECTION OF ALL AREAS INDICATED TO REMAIN UNDISTURBED OR TO REMAIN AS BUFFERS, ALL PROPERTY CORNERS, AND REPLACING ALL PINS ELIMINATED OR DAMAGED DURING CONSTRUCTION.
- CONTRACTOR IS RESPONSIBLE FOR REPAIRS OR DAMAGE TO ANY EXISTING IMPROVEMENTS DURING CONSTRUCTION, SUCH AS, BUT NOT LIMITED TO, DRAINAGE, UTILITIES, PAVEMENT, STRIPING, CURB, ETC., REPAIRS SHALL BE EQUAL TO OR BETTER THAN EXISTING CONDITIONS.
- THE SITE CONTRACTOR SHALL COORDINATE THE INSTALLATION OF ALL UNDERGROUND UTILITIES WITH HIS WORK. ALL UNDERGROUND UTILITIES (WATER, SANITARY SEWER, STORM SEWER, ELECTRICAL CONDUIT, IRRIGATION SYSTEMS, AND ANY OTHER MISC. UTILITIES) SHALL BE IN PLACE PRIOR TO THE PLACEMENT OF BASE COURSE MATERIAL, AND THE PLACEMENT OF ANY APPROPRIATE SOIL STABILIZATION TECHNIQUE.
- CONTRACTOR SHALL PROVIDE BOLLARDS FOR PROTECTION OF ALL ABOVE GROUND UTILITIES AND APPURTENANCES ADJACENT TO DRIVE AREAS.
- CONTRACTOR SHALL MATCH EXISTING PAVEMENT IN GRADE AND ALIGNMENT.
- CONSTRUCTION SHALL COMPLY WITH ALL GOVERNING CODES AND BE CONSTRUCTED TO THE SAME.
- ALL STRIPING SHALL COMPLY WITH THE MANUAL ON UNIFORM TRAFFIC CONTROL DEVICES LATEST EDITION.
- ANY WORK IN THE RIGHT OF WAY SHALL BE PERFORMED IN ACCORDANCE WITH MICHIGAN DEPARTMENT OF TRANSPORTATION AND DEVELOPMENT'S STANDARD DRAWINGS AND SPECIFICATIONS.
- SITE ZONED DP.

SITE LAYOUT NOTES:

- TOTAL BUILDING AREA = .65 ACRES.
- DIMENSIONS ARE TO FACE OF MATERIAL UNLESS OTHERWISE NOTED.
- ALL RADII ARE 5 FEET UNLESS OTHERWISE NOTED.
- SEE CIVIL DRAWINGS FOR DETAILS.

PARKING ANALYSIS:

PARKING AS PER ORDINANCE 744, Art IV
 EXISTING PARKING EXPANDED AS PER SECTION 1, EXEMPTION E
 PARKING EVALUATED PER SECTION 2
 TABLE 744-402-1

MAIN FLOOR 1575 SF OFFICE / 350 = 4.5 = 5 SPACES REQUIRED	6 SPACES REQUIRED/ 7 PROVIDED (2 ADA: 1 STANDARD- 1 VAN)
MAIN FLOOR 284 SF RETAIL / 350 = .8 = 1 SPACE REQUIRED	3 BICYCLE RACK ON NORTH SIDE OF BLDG
	ADDITIONAL EXISTING PARKING ON SITE FOR OTHER OFFICE (SECOND FLOOR) 2280 SF / 350 = 6.5 = 7 SPACES

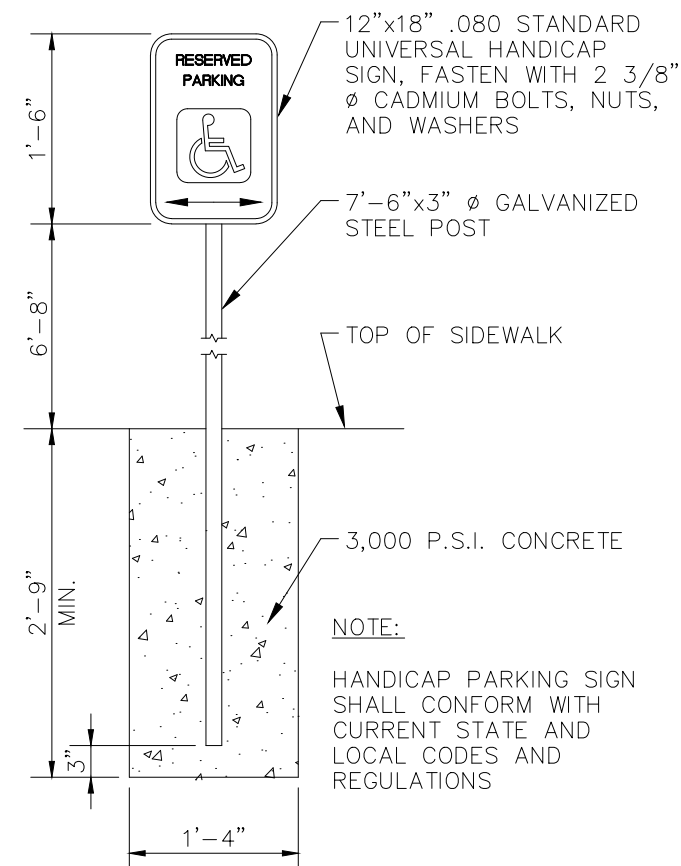

HANDICAP PARKING SIGN
 SCALE: NTS

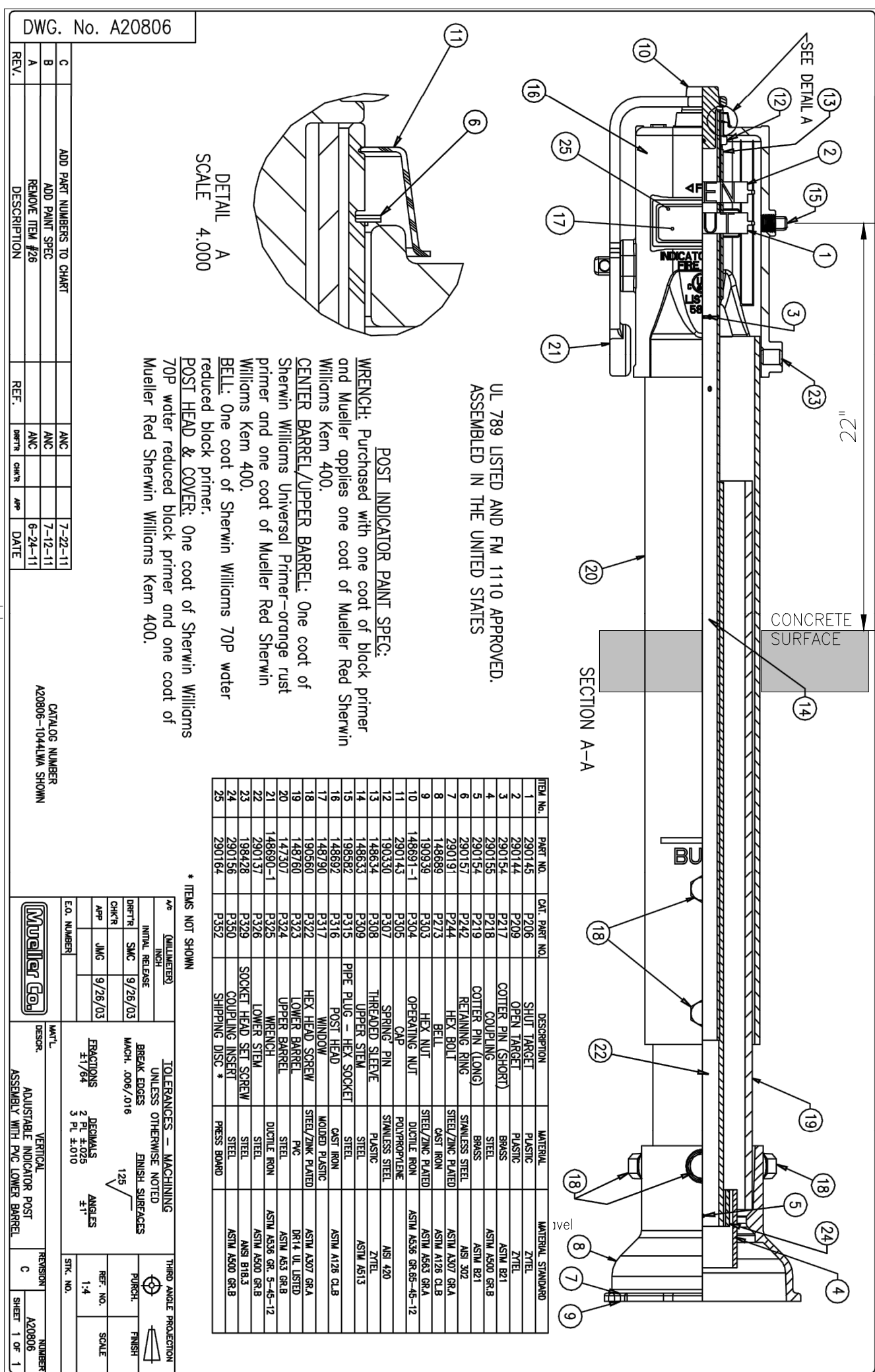

PIV VALVE
 SCALE: NTS

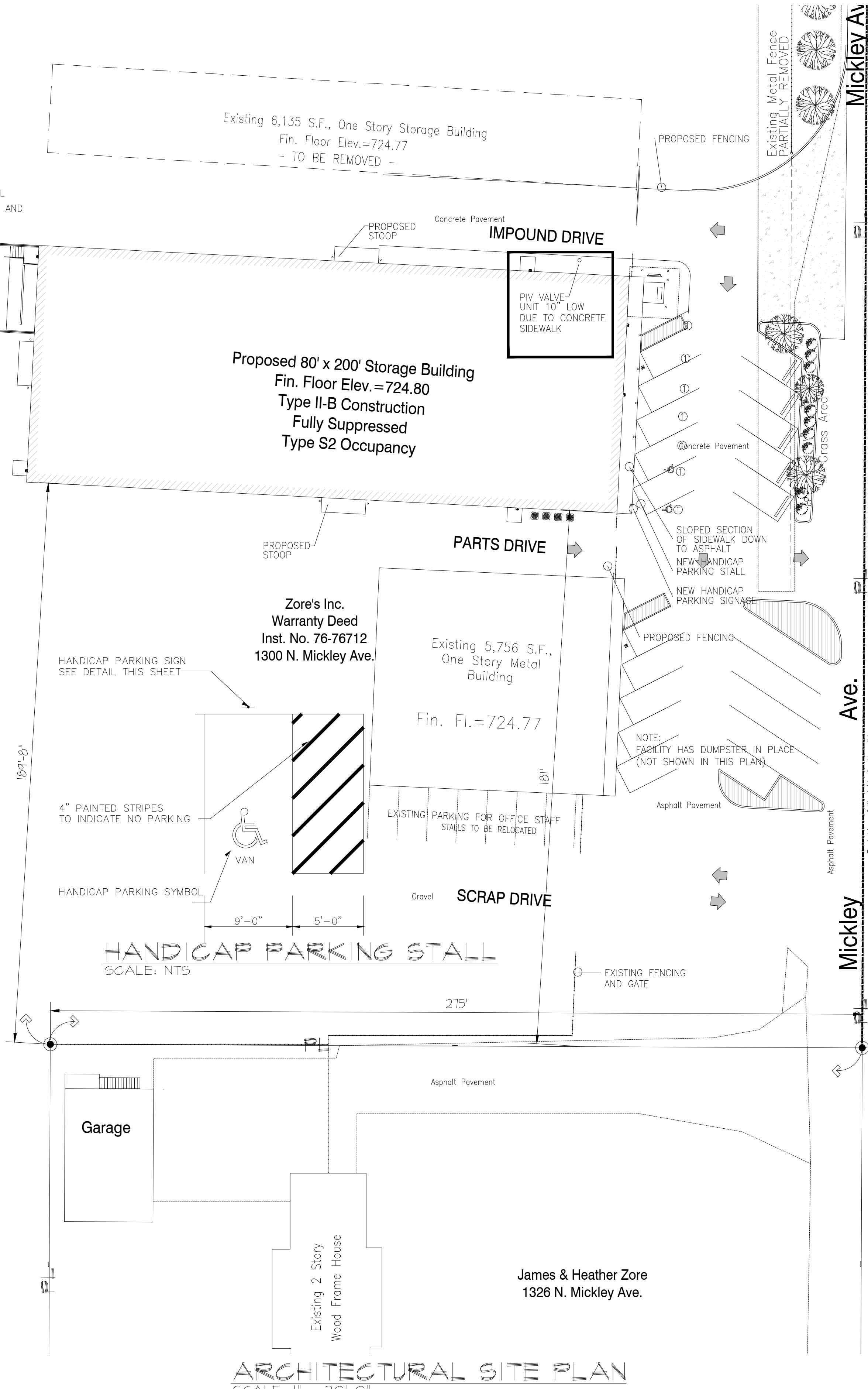

ARCHITECTURAL SITE PLAN
 SCALE: 1" = 20'-0"

LEGEND

- RESIDENTIAL LOCAL STREET
- 4" CONC. WALK
- FULL DEPTH GRANULAR BACKFILL PER LAWRENCE STD. 92-01
- PROPOSED WATER MAIN
- PROPOSED SANITARY SEWER & MH
- PROPOSED 6" SANITARY SEWER LATERAL
- PROPOSED STORM SEWER & STREET INLET
- PROPOSED STORM SEWER & YARD INLET
- PROPOSED STORM SEWER & MANHOLE
- 4" SUBSURFACE DRAIN
- SIDEWALK CURB RAMPS
- SANITARY SEWER CLEANOUT
- COPPERWELD STREET MONUMENT
- STREET SIGN
- TRAFFIC SIGN AS INDICATED
- HARRISON STREET MONUMENT
- EXISTING SANITARY SEWER
- EXISTING STORM SEWER
- FUTURE SANITARY SEWER
- FUTURE STORM SEWER

This property is located in Zone X as shown on F.I.R.M. Number 18097C0117 G dated April 19, 2016.

NOTE: This site is currently operating under a "No Discharge" Exemption, Industrial Storm Water permit, INRM01331.

811
 Know what's below.
 Call before you dig.



JACK P. MORGAN
 AIA CSI - ARCHITECT
 7062 N. TUXEDO STREET
 INDIANAPOLIS, IN 46220
 PH: 317-508-4516 FAX: 317-820-3405
 e-mail: morwalsopladi@gmail.com

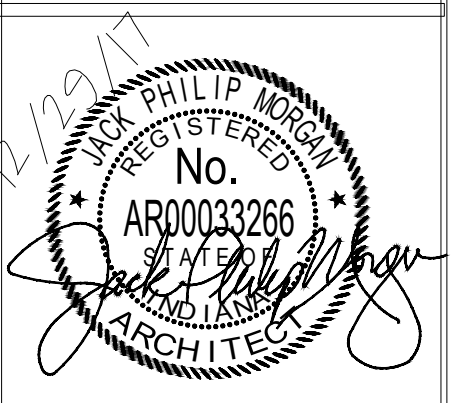

DATE: 12/29/17
 ISSUE: FILING/ REVIEW

PROPOSED DESIGN FOR:
ZORE'S SERVICE BUILDING
 BUILDING 7
 1300 N. MICKLEY ROAD
 INDIANAPOLIS, IN