



October 30, 2019
By Electronic Mail and U.S. Postal Mail

Melissa M. Tupper
RTM Consultants, Inc.
6640 Parkdale Place, Suite J
Indianapolis, IN 46254-4698
tupper@rtmconsultants.com

Re: Petition for Administrative Review – Variance No. 19-09-36 – ER Vision New Office Building

Dear Ms. Tupper:

The Fire Prevention and Building Safety Commission is in receipt of your petition for administrative review of Variance No. 19-09-36 – ER Vision New Office Building, dated 10/23/2019. The petition for review is timely and has been granted by the Commission. The petition has been assigned to the Commission’s administrative law judge.

The judge’s office will contact you to make arrangements for further proceedings. Should you have any questions, you may contact our deputy general counsel assigned to the matter, Justin Guedel at jguedel@dhs.in.gov or (317) 234-9515.

Sincerely,

Douglas J. Boyle, Director
Fire Prevention and Building Safety Commission
Indiana Department of Homeland Security
302 W. Washington Street, Room E-208
Indianapolis, IN 46204
doboyle@dhs.in.gov
(317) 650-7720

Enclosure

cc: Justin Guedel, IDHS Deputy General Counsel – representing the respondent (by personal service and electronic mail)
Office of Attorney General Curtis Hill – Administrative Law Judge (by electronic mail)
File

October 23, 2019

Douglas J. Boyle
Director - Fire Prevention and Building Safety Commission
c/o Office of the General Counsel
Department of Homeland Security
302 W. Washington Street Room E-208
Indianapolis, Indiana 46204

**ER Vision New Office Building
Request for Administrative Review - Variance 19-09-36**



BUILDING CODES



FIRE PROTECTION



JCAHO/CMS/HFAP

Dear Doug:

On behalf of the owner, this letter is a petition for review to the Fire Prevention and Building Safety Commission regarding the denial of Variance 19-09-36.

Thank you for your attention to this matter. If you have any questions, please let us know.

Sincerely,

RTM Consultants, Inc.

A handwritten signature in blue ink that reads "Melissa M. Tupper".

Melissa M. Tupper, P.E.
Principal
Fire Protection Engineer

Indiana Department of Homeland Security
302 W. Washington Street
Indianapolis, IN 46204

OCT 23 2019

RTM

CONSULTANTS, INC.

RTM CONSULTANTS, INC.
6640 Parkdale Place, Suite J
INDIANAPOLIS, IN 46254-4698

RECEIVED
IDHS

OCT 23 2019

COMMISSION
STAFF

Douglas Boyle
Indiana Department of Homeland Security
Fire Prevention and Building Safety Commission
302 W. Washington Street, Rm E208
Indianapolis, IN 46204

BUILDING CODES ♦ FIRE PROTECTION ♦ JCAHO/CMS/HFAP



ERIC J. HOLCOMB, Governor
STATE OF INDIANA

DEPARTMENT OF HOMELAND SECURITY

BRYAN J. LANGLEY, EXECUTIVE DIRECTOR

Indiana Department of Homeland Security
Indiana Government Center South
302 West Washington Street
Indianapolis, IN 46204
317-232-3980

Tracy Witte
ER Vision, LLC
11020 DIEBOLD ROAD

October 8, 2019

FORT WAYNE, IN 46845

Dear Tracy Witte,

This letter provides notice of the action taken on your application(s) for a variance(s) from the Commission's rules under IC 22-13-2-11.

Project Number	Project Name	Variance Number
0	ER Vision New Office Building	19-09-36

Conditions

Edition	Code	Code Section	Action & Date
	Other Code (Not in the list provided)	2014 IBC, 1018.1	Not Approved 09/24/2019

If you have any questions regarding this order, you may contact that Department at (317) 232-2222.

ADMINISTRATIVE REVIEW

If you desire administrative review of this order, you must comply with the requirements of Indiana Code IC 4-21.5-3-7 and file a written petition for review within fifteen (15) days after receiving notice of this order. Your petition for review must state facts demonstrating that you are:(1) a person to whom the order is specifically directed; (2) aggrieved or adversely affected by the order; or (3) entitled to review under any law. You may submit your petition by one of the following methods:

U.S.MAIL OR PERSONAL SERVICE

Indiana Department of Homeland Security
Fire Prevention and Building Safety Commission
302 W.Washington Street, Rm. E208
Indianapolis, IN 46204

ONLINE

By completing the form at
<https://www.in.gov/dhs/appeals.htm>

For additional information about the administrative review process and applicable templates that may be used for filings, visit the following link

<https://www.in.gov/dhs/appeals.htm>

From: [Melissa Tupper](#)
To: [IDHS Variances](#)
Cc: [Tracy Witte](#)
Subject: RE: Notice of Proposed Order of Denial of Variance No. 19-09-36 (ID #19680)
Date: Monday, September 30, 2019 5:35:06 PM
Attachments: [image001.png](#)

****** This is an EXTERNAL email. Exercise caution. DO NOT open attachments or click links from unknown senders or unexpected email. ******

We would ask that you reconsider approving the variance provided a fire alarm system is installed throughout the building and a smoke detection system is installed in the corridors and areas open to the corridors. Neither of these systems are required by code. Similar variances have been granted for new corridors in B Occupancy buildings and spaces, including 18-03-33, 18-02-15, 18-02-29, 17-05-40, 13-03-36a, 13-03-36b, 17-08-09, 17-08-56, 11-06-32, 12-10-28, 13-03-45, 16-03-23, 16-06-56, 16-06-61, 15-01-33, 15-06-54, 16-07-11, and 16-07-27.

If you have any questions, please contact us.

Sincerely,

Melissa M. Tupper, P.E.
Principal
Fire Protection Engineer

RTM Consultants, Inc.
6640 Parkdale Place, Suite J
Indianapolis, IN 46254

(317) 329-7700 ext 104
(317) 329-8411 fax

From: IDHS Variances <Variances@dhs.IN.gov>
Sent: Thursday, September 26, 2019 4:20 PM
To: TRACY@ENGINEERINGRESOURCESINC.COM; Melissa Tupper <tupper@rtmconsultants.com>
Cc: kurt@engineeringresourcesinc.com; john.caywood@co.allen.in.us; mike.feelyhfd@gmail.com; Boyle, Douglas J (DHS) <DoBoyle@dhs.IN.gov>; Fitzpatrick, Denise <dfitzpatrick@dhs.IN.gov>; Burgess, Craig <CBurgess@dhs.IN.gov>; Hyten, Kim R <KHyten@dhs.IN.gov>; Vanblaricum, Karla <KVanblaricum@dhs.IN.gov>; Guedel, Justin K <JGuedel@dhs.IN.gov>
Subject: Notice of Proposed Order of Denial of Variance No. 19-09-36 (ID #19680)

Dear Ms. Whitte and Ms. Tupper,

The Department has reviewed your application for a variance and intends to deny your request. Please see the attached notice for additional information regarding this proposed action and options available to you if you disagree with this proposed action.

IDHS Variances Section

Indiana Department of Homeland Security
Indiana Government Center South – Second Floor
302 W. Washington Street
Indianapolis, IN 46204
Tel: (317) 232-1402
Email: variances@dhs.in.gov
Web: <http://www.in.gov/dhs/4290.htm>





NOTICE OF PROPOSED ORDER OF DENIAL

Variance Number: 19-09-36

Variance ID: 19680

Applicant: Tracy Witte

Submitter: Melissa Tupper

The Indiana Department of Homeland Security (“Department”) has reviewed your application for a variance and intends to deny your request for the following reason(s):

- The request does not demonstrate a sufficient undue hardship, and does not sufficiently demonstrate that public health, life, safety and welfare will be protected. The variance applications approved in the past are not similar to this variance application (19-06-71 and 18-09-37 were approved for to projects of existing construction and/or additions to existing construction, as opposed completely new construction, as is the case for this project.

If you disagree with the reason(s) mentioned above and would like to provide additional information addressing the Department’s reasons for denial, please submit your response in writing to variances@dhs.in.gov within five (5) business days of receiving this notice. Upon receipt of your response, the Department will review the information provided and issue an appropriate order. If you do not provide any additional information within the time period mentioned above, the Department will move forward with denial of your request.

Owner / Applicant Information

Tracy Witte
ER Vision, LLC
11020 DIEBOLD ROAD

FORT WAYNE IN 46845

Phone 2604519710

Email TRACY@ENGINEERINGRESOURCESINC.COM

Submitter Information

Melissa Tupper
RTM Consultants, Inc.
6640 Parkdale Place

Indianapolis IN

Phone 3173297700

Email tupper@rtmconsultants.com

Designer Information

Kurt Heidenreich
Engineering Resources, Inc.
11020 Diebold Road

Fort Wayne IN

Phone 2604519700

Email kurt@engineeringresourcesinc.com

Project Information

ER Vision New Office Building
4175 New Vision Drive

Fort Wayne IN

County ALLEN

Project Type New Addition Alteration Existing Change of Occupancy

Project Status U F=Filed U or Null=Unfiled

IDHS Issued Correction order? Has Violation been Issued?

Violation Issued by: NA

Local Building Official

Phone: Email:

Local Fire Official

Phone: Email:

Variance Details

Code Name: Other Code (Not in the list provided)

2014 IBC, 1018.1

Conditions: The variance request is to permit corridor walls and doors to be non-rated construction in the new office building. Based upon serving a calculated occupant load of 30 or more, 1-hour fire-rated corridor construction is required.

The project involves a new 1-story office building, with small second floor for storage of testing equipment. The building is Type VB construction, the overall 1st floor is 17,895 sf and the 2nd floor is 430 sf. The building is divided in two by a 2-hour fire wall.

DEMONSTRATION THAT PUBLIC HEALTH, SAFETY, AND WELFARE ARE PROTECTED:

- 1=Non-compliance with the rule will not be adverse to the public health, safety or welfare.
- 2= Applicant will undertake alternative actions in lieu of compliance with the rule to ensure that granting of the variance will not be adverse to public health, safety, or welfare. Explain why alternative actions would be adequate (be specific).

Facts: 1. NFPA 101, Life Safety Code, Sec. 38.3.6, exc. 2, permits non-rated corridors in a B Occupancy tenant space since it is a space occupied by a single tenant.

2. The maximum travel distance to an exit is approximately 100 feet, code permits up to 200 feet.

3. Similar variances have been granted for office build-outs, including 19-06-71 and 18-09-37.

DEMONSTRATION OF UNDUE HARDSHIP OR HISTORICALLY SIGNIFICANT STRUCTURE:

- Imposition of the rule would result in an undue hardship (unusual difficulty) because of physical limitations of the construction site or its utility services.
- Imposition of the rule would result in an undue hardship (unusual difficulty) because of major operational problems in the use of the building or structure.
- Imposition of the rule would result in an undue hardship (unusual difficulty) because of excessive costs of additional or altered construction elements.
- Imposition of the rule would prevent the preservation of an architecturally or a historically significant part of the building or structure.

Facts: The hardship is the cost providing floor-to-deck fire partitions to separate the corridor and providing rated doors with closers. It is an operational hardship to have closers on all of the office doors. In addition providing rated corridors would not permit for the design of open office areas.

CERTIFICATION

New Office Building for:
ER Vision, LLC
 4175 New Vision Dr.
 Fort Wayne, Indiana 46845

The concepts, ideas, designs, plans and details as shown on this document are the sole property of Engineering Resources, Inc. and were created, developed, and presented for use on this specific project. None of the concepts, ideas, designs, plans, or details shall be used or dissemination of any data herein may be made without the written permission of Engineering Resources, Inc.

REVISIONS	
DATE	DESCRIPTION
08/22/2019	DATE ISSUED
	PLOT SCALE

FIRST & SECOND FLOOR PLANS
A2.1



SECOND FLOOR PLAN
 SCALE: 1/8" = 1'-0"
 NORTH

FIRST FLOOR PLAN
 SCALE: 1/8" = 1'-0"
 NORTH

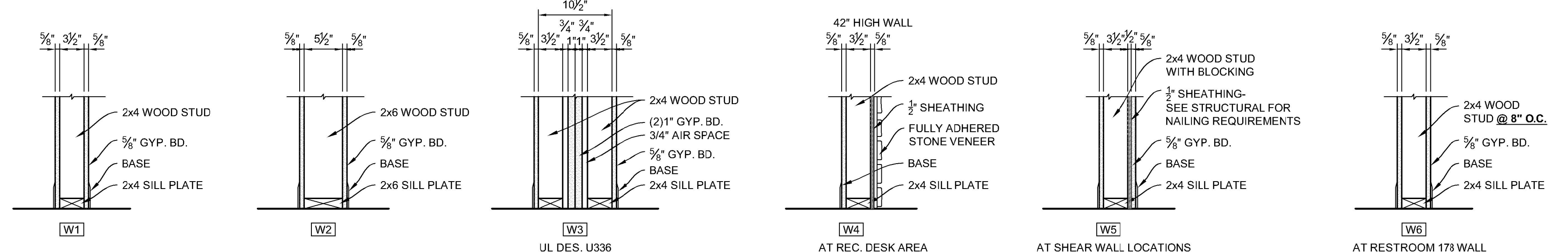

WALL TYPES
 SCALE: 1" = 1'-0"

PLAN NOTES:
 1. 22 1/2" X 48" HINGED ATTIC ACCESS DOOR (INSULATED).
 2. 22 1/2" X 48" ATTIC INSULATED ACCESS PANEL ABOVE SUSPENDED CEILING GRID.
 3. PLACE DRYWALL CONTROL JOINTS IN HALLWAYS NEAR BULKHEADS AND/OR 30" O.C. WHERE THERE IS NO PERIMETER RELIEF.

August 30, 2019, 8:42 AM S:\Projects\Projects (1000-1999)\Projects (1300-1349)\1300-ER Bldg\Drawings\Arch\A2.1 - Floor Plans.dwg

CERTIFICATION

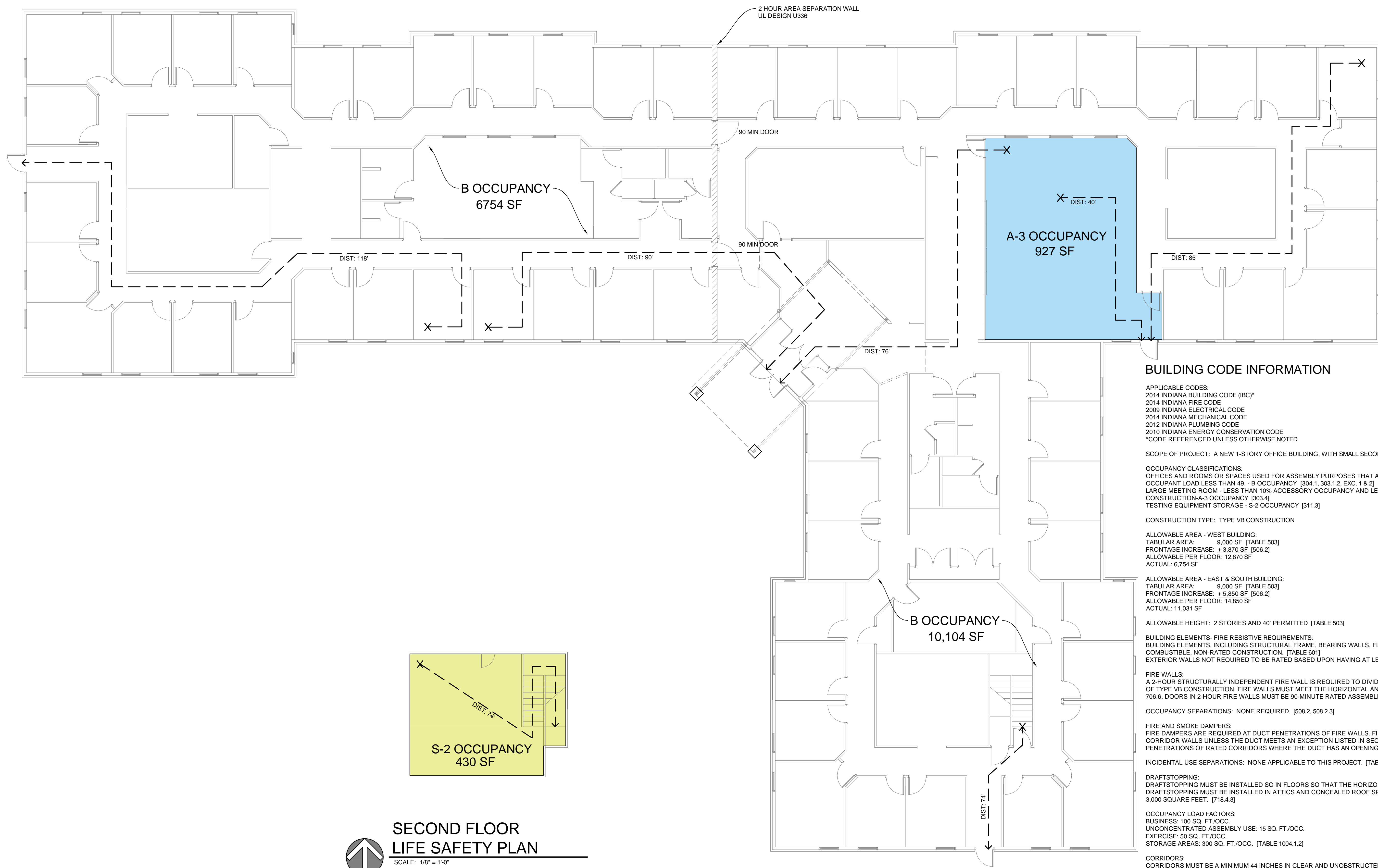

BUILDING CODE INFORMATION

APPLICABLE CODES:
 2014 INDIANA BUILDING CODE (IBC)*
 2014 INDIANA FIRE CODE
 2009 INDIANA ELECTRICAL CODE
 2014 INDIANA MECHANICAL CODE
 2012 INDIANA PLUMBING CODE
 2010 INDIANA ENERGY CONSERVATION CODE
 *CODE REFERENCED UNLESS OTHERWISE NOTED

SCOPE OF PROJECT: A NEW 1-STORY OFFICE BUILDING, WITH SMALL SECOND FLOOR FOR STORAGE.

OCCUPANCY CLASSIFICATIONS:
 OFFICES AND ROOMS OR SPACES USED FOR ASSEMBLY PURPOSES THAT ARE LESS THAN 750 SQUARE FEET IN AREA OR HAVE A CALCULATED OCCUPANT LOAD LESS THAN 49 - B OCCUPANCY [304.1, 303.1.2, EXC. 1 & 2]
 LARGE MEETING ROOM - LESS THAN 10% ACCESSORY OCCUPANCY AND LESS THAN TABULAR AREA OF 6,000 SQUARE FEET FOR TYPE VB CONSTRUCTION-A-3 OCCUPANCY [303.4]
 TESTING EQUIPMENT STORAGE - S-2 OCCUPANCY [311.3]

CONSTRUCTION TYPE: TYPE VB CONSTRUCTION

ALLOWABLE AREA - WEST BUILDING:
 TABULAR AREA: 9,000 SF [TABLE 503]
 FRONTAGE INCREASE: + 3,870 SF, [506.2]
 ALLOWABLE PER FLOOR: 12,870 SF
 ACTUAL: 6,754 SF

ALLOWABLE AREA - EAST & SOUTH BUILDING:
 TABULAR AREA: 9,000 SF [TABLE 503]
 FRONTAGE INCREASE: + 5,850 SF, [506.2]
 ALLOWABLE PER FLOOR: 14,850 SF
 ACTUAL: 11,031 SF

ALLOWABLE HEIGHT: 2 STORIES AND 40' PERMITTED [TABLE 503]

BUILDING ELEMENTS - FIRE RESISTIVE REQUIREMENTS:
 BUILDING ELEMENTS, INCLUDING STRUCTURAL FRAME, BEARING WALLS, FLOORS, AND ROOFS PERMITTED TO BE A MINIMUM OF COMBUSTIBLE, NON-RATED CONSTRUCTION. [TABLE 601]
 EXTERIOR WALLS NOT REQUIRED TO BE RATED BASED UPON HAVING AT LEAST 10 FEET OF FIRE SEPARATION DISTANCE. [TABLE 602]

FIRE WALLS:
 A 2-HOUR STRUCTURALLY INDEPENDENT FIRE WALL IS REQUIRED TO DIVIDE THE BUILDING TO PERMIT THE BUILDING TO BE CONSTRUCTED OF TYPE VB CONSTRUCTION. FIRE WALLS MUST MEET THE HORIZONTAL AND VERTICAL CONTINUITY REQUIREMENTS OF SECTIONS 706.5 AND 706.6. DOORS IN 2-HOUR FIRE WALLS MUST BE 90-MINUTE RATED ASSEMBLIES AND SELF OR AUTOMATIC CLOSING. [706, TABLE 716.5]

OCCUPANCY SEPARATIONS: NONE REQUIRED. [508.2, 508.2.3]

FIRE AND SMOKE DAMPERS:
 FIRE DAMPERS ARE REQUIRED AT DUCT PENETRATIONS OF FIRE WALLS. FIRE DAMPERS ARE REQUIRED AT DUCT PENETRATIONS OF RATED CORRIDOR WALLS UNLESS THE DUCT MEETS AN EXCEPTION LISTED IN SECTION 717.5.4. SMOKE DAMPERS ARE REQUIRED AT DUCT PENETRATIONS OF RATED CORRIDORS WHERE THE DUCT HAS AN OPENING INTO THE CORRIDOR. [717.5]

INCIDENTAL USE SEPARATIONS: NONE APPLICABLE TO THIS PROJECT. [TABLE 509]

DRAFTSTOPPING:
 DRAFTSTOPPING MUST BE INSTALLED SO IN FLOORS SO THAT THE HORIZONTAL FLOOR AREAS DO NOT EXCEED 1,000 SQUARE FEET. [718.3.3]
 DRAFTSTOPPING MUST BE INSTALLED IN ATTICS AND CONCEALED ROOF SPACES, SUCH THAT ANY HORIZONTAL AREA DOES NOT EXCEED 3,000 SQUARE FEET. [718.4.3]

OCCUPANCY LOAD FACTORS:
 BUSINESS: 100 SQ. FT./OCC.
 UNCONCENTRATED ASSEMBLY USE: 15 SQ. FT./OCC.
 EXERCISE: 50 SQ. FT./OCC.
 STORAGE AREAS: 300 SQ. FT./OCC. [TABLE 1004.1.2]

CORRIDORS:
 CORRIDORS MUST BE A MINIMUM 44 INCHES IN CLEAR AND UNOBSTRUCTED WIDTH. A MINIMUM OF 36 INCHES IS PERMITTED WHERE SERVING AN OCCUPANT LOAD LESS THAN 50. [TABLE 1018.2]
 CORRIDORS ARE REQUIRED TO BE 1-HOUR RATED CONSTRUCTION BASED UPON SERVING 30 OCCUPANTS. DOORS MUST BE 20 MINUTE RATED AND SELF CLOSING. [TABLE 1018.1]
 RATED CORRIDORS MUST BE CONTINUOUS FROM THE POINT OF ENTRY TO AN EXIT AND CANNOT BE INTERRUPTED BY INTERVENING ROOMS. [TABLE 1018.6]

PANIC HARDWARE:
 PANIC HARDWARE IS REQUIRED FOR DOORS THAT LATCH SERVING A OCCUPANCIES WHERE THE ROOM OR AREA HAS AN OCCUPANT LOAD OF 50 OR MORE. [1008.1.10]

EXIT TRAVEL DISTANCE:
 COMMON PATH OF TRAVEL MUST NOT EXCEED 75 FEET. [TABLE 1014.3]
 THE MAXIMUM TRAVEL DISTANCE TO AN EXTERIOR EXIT IS 200 FEET FOR A AND B OCCUPANCIES. [TABLE 1016.2]

NUMBER OF EXITS:
 2 EXITS REQUIRED PER FLOOR FOR AN OCCUPANT LOAD OF 1-500 [1021.2]
 A SINGLE EXIT IS PERMITTED FROM THE 2ND FLOOR WHERE THE OCCUPANT LOAD DOES NOT EXCEED 28 AND THE TRAVEL DISTANCE TO AN EXTERIOR EXIT DOES NOT EXCEED 75 FEET. [TABLE 1021.2(2)]

AUTOMATIC SPRINKLERS:
 AUTOMATIC SPRINKLERS ARE NOT REQUIRED FOR B AND S-2 OCCUPANCIES OR FOR A-3 OCCUPANCIES WITH A FIRE AREA LESS THAN 12,000 SQUARE FEET AND OCCUPANT LOAD LESS THAN 300. [903.2.1.3]

FIRE ALARM SYSTEM:
 A FIRE ALARM SYSTEM IS NOT REQUIRED BASED UPON THE CALCULATED OCCUPANT LOAD OF THE A OCCUPANCY NOT EXCEEDING 300 AND THE CALCULATED OCCUPANT LOAD OF THE B OCCUPANCY NOT EXCEEDING 500 OCCUPANTS. [907.2.1, 907.2.2]

SMOKE DETECTORS:
 SMOKE DETECTORS MUST BE INSTALLED IN NEW SUPPLY AIR SYSTEMS WITH A DESIGN CAPACITY GREATER THAN 2,000 CFM, IN THE SUPPLY AIR DUCT. [606.2, IMC]

SECOND FLOOR LIFE SAFETY PLAN
 SCALE: 1/8" = 1'-0"

FIRST FLOOR LIFE SAFETY PLAN
 SCALE: 1/8" = 1'-0"

New Office Building for:
ER Vision, LLC
 4175 New Vision Dr.
 Fort Wayne, Indiana 46845

The concepts, ideas, designs, plans and details as shown on this document are the sole property of Engineering Resources, Inc. and were created, developed, and presented for use on this specific project. None of the concepts, ideas, designs, plans, or details shall be used or dissemination of any data herein may be made without the written permission of Engineering Resources, Inc.

DATE	ISSUED	08/22/2019
PLOT SCALE		
REVISIONS		
DATE	DESCRIPTION	